

◎解答はすべて解答用紙に記入しなさい。

I 次のAyaさんのタイ王国への研修旅行の英文を読んで、あとの問いに答えなさい。

We, eight high school students and two teachers arrived at Bangkok International Airport, Thailand on July 19, 2015. Teachers of Khema Siri Memorial School met us at the airport and we went directly (1) a hotel by car. After taking a rest at the hotel for a while, we went to a nearby river to have dinner on the boat. As it was (ア) [get] dark, we could see temples \*illuminated by bright lights. We realized we were in Thailand, the country of Buddhism. We enjoyed watching Thai dance and songs ( ① ) were sung by some entertainers and also enjoyed (イ) [have] Thai food for the first time. ( ② ), they found that we were from Japan. So, they played Japanese animation songs for us. We were very happy. We enjoyed the dinner on the boat very much.

On the second day, we visited Khema Siri Memorial School for the first time. We were warmly welcomed. Before we went in to a hall, we offered flowers and bowed to the statue of the school \*founder. Then, we attended a welcome ceremony. Thai students showed us Thai dance. It was so rhythmical and comfortable that we really enjoyed it. After the ceremony, we were (ウ) [take] to the library. The elementary school pupils were drawing the pictures of Queen there. In Thailand, people love a royal family. They love and respect King and Queen very much. We can see the pictures of King everywhere in the country. Then we went to a dining hall to have lunch. All the pupils and students at Khema Siri Memorial School eat lunch in the dining hall. It was very delicious and we enjoyed lunch.

After lunch, we learned Thai manners. There were many kinds (2) manners. It was very difficult for us to do. But students and teachers at Khema Siri Memorial School showed us politely and carefully. Then we learned traditional Thai design with gold leaf. The art teacher showed us how to make the design and we tried. At the beginning it looked easy to make. But the gold leaf \*sticked to our fingers easily. So, it turned out to be very difficult. We finally completed our designs. It was a valuable experience.

After school we met our host families. At first, I was very nervous and couldn't talk with them. I couldn't follow their speech in English. I couldn't make myself (エ) [understand], either. But they talked to me with a smile. They were very kind and I was very thankful. I felt as if they were my new family in Thailand.

On the third day, we made a speech in the \*morning assembly in front of all the pupils and students. I myself felt a little nervous, but I could make a speech in English with relaxed mood. After that, we learned Thai alphabet and numbers. (I) It is the first time that I have ever learned Thai alphabet. It was very difficult to write. But, Thai students taught us how to write letters one (3) one, so I was able to write my name in Thai.

In the Japanese lesson, we had a gesture game and memorization game using Thai and Japanese language. It was difficult to lead the game. However, it was a good chance to understand different culture. (II) We enjoyed the game so much that we almost forgot lunch time. We were given Extra Thai massage by the students at Khema Siri Memorial School. They were the same age (4) ours. But they really did well. I felt (オ) [relax] by having a massage.

After that, we taught Thai students and teachers *Shodo, Origami, Sado, and Chigirie and Uchiwa*. They were very (カ) [interest] in Japanese traditional culture. They showed deep interest in these things. Through the \*exchange, we learned that Thai students had deep interest in Japan and Japanese. And I also learned the importance of understanding each other. We were able to \*deepen mutual understanding of Thai and Japanese cultures through this exchange program.

On the fourth day in Bangkok, (5) the way back to our hotel, when we were passing by some school area, (III) ( ① along ② I ③ lining ④ many cars ⑤ saw ⑥ the school fence). I asked the guide why so many cars were waiting in front of the school. She said that in Bangkok many parents would come to school to pick up their sons and daughters by car or by bike. I saw three or four people riding on the small bike! It seemed to be very dangerous. In Bangkok, it is not unusual for three or four people to ride on the same bike. I also saw many people eating meals at stands on the street. In Bangkok, many women work for companies. They are busy, so they don't have enough time to make supper for their families. Many people and families eat out. They also eat breakfast at stands (5) the way to work or school.

We stayed in Bangkok for six days. However, time flew so fast and we went home with many good memories. Through our stay in Thailand, we were able to deepen our understanding of Thailand and strengthen our friendship between Harima and Khema Siri Memorial School. I also learned a very important thing. As the \*proverb says, ③ "To see is to ( )." To understand each other well, there is no \*substitute for staying and studying (6) each other's country. Through the exchange program I believe that \*mutual understanding and friendship will be deepened more and more.

[注] illuminate 照らす founder 創設者 stick 貼り付ける morning assembly 朝礼 exchange 交流 deepen 深める  
proverb ことわざ substitute 代わりとなるもの mutual 相互の

問1 (1)~(6)に入る適切な語を下の語群から選び記号で答えなさい。

ア as イ by ウ in エ to オ of カ on

問2 (ア) ~ (カ) 内の動詞を適切な形に直しなさい。

問3 ①~③の問題に答えなさい。

1 ①には正しい答えを次から選びその番号を書きなさい。

1) who 2) which 3) whom

2 ②には「しばらくして」の意味になるように、次から選びその番号を書きなさい。

1) on a while 2) after a while 3) for a while

3 ③の下線部が「百聞は一見にしかず」の意味になるように、( )に英単語を書きなさい。

問4 下線部(I)、(II)、(III)の問題に答えなさい。

1 下線部(I)の意味に合うものを選びその記号を書きなさい。

- a. 今までにタイ語を勉強したことがあります。  
b. タイ語を勉強したのはこれが初めてです。  
c. 第1言語にタイ語を選びます。

2 下線部(II)の意味に合うものを選びその記号を書きなさい。

- a. 私達はゲームを楽しんだので昼ごはんを食べなかった。  
b. 私達はゲームがあまりにも楽しかったので昼食の時間をすっかり忘れてしまった。  
c. 私達はゲームをとっても楽しんだので昼食の時間をあやうく忘れるところだった。

3 下線部(III)を「たくさんの車が学校のフェンス沿いに並んでいるのを見ました。」の意味に合うように、英単語を並べかえ英文を完成し、3番目と5番目にくる語(句)を番号で答えなさい。

問5 本文の内容に関して次の質問の答えとなる文の ( ) の中に適切な英単語を入れなさい。

- 1 What date did Aya visit Khema Siri Memorial School?  
She visited the school on ( ) ( ), 2015.
- 2 Where was a welcome ceremony held?  
It was held at ( ) ( ).
- 3 When did they make a speech in the morning?  
They made a speech on the ( ) ( ).
- 4 Why do many people in Bangkok eat meals at stands?  
Because many women ( ) for companies and they are ( ).
- 5 How many days did Aya stay in Bangkok?  
She stayed in Bangkok ( ) ( ) ( ).

問6 本文の内容に合っているものにはTを、合っていないものにはFと答えなさい。

- 1 The students who did a massage for us were older than Aya.
- 2 Thai students showed little interest in Japanese traditional culture.
- 3 Many Thai students eat breakfast at the stand.
- 4 Many parents in Bangkok come to school to pick up their children.
- 5 It is important to meet face to face to understand each other well.

II 次の1と2の英文を読むとき1か所区切るとすれば、それぞれどこで区切るのが最も適切か、ア～エの中から選びその記号で答えなさい。

- 1 The woman who fell in love is Canadian.  
ア イ ウ エ
- 2 Christine's parents were very proud of her when she got a good score on her exam.  
ア イ ウ エ

III 次の1～3の対話文を読んで、それぞれの下線部ア～オの語(句)のうち、最も強く発音する語(句)を1つ選びその記号で答えなさい。

- 1 A: Did your grandfather take his grandchildren to the zoo this summer vacation?  
B: No, he didn't. He took them to the swimming pool.  
ア イ ウ エ オ
- 2 A: Ms. Smith is going back home to her country next month.  
B: Yeah, I heard that. Let's give her something nice together.  
ア イ ウ エ オ
- 3 A: Where do you get off the bus?  
B: I get off at the last terminal  
ア イ ウ エ オ

IV 次の会話文の空所に入れるのに最も適当なものを①～③の中から1つ選び、その番号で答えなさい。

- 1 A: Would you like something cold to drink?  
B: Yes, please. ( )  
A: Sure.  
① I get angry.  
② Don't mind.  
③ I'm very thirsty.
- 2 A: What do you think of her clothes, Mary?  
B: ( ) Especially, the blouse is nice.  
A: Yes, it goes well with the skirt.  
① I think it's mine.  
② I think her clothes are very stylish.  
③ That's kind of you.
- 3 A: Hello, this is George. May I speak to Taro, please?  
B: I'm sorry, but ( )  
A: Sorry. I must have the wrong number.  
① this is Taro, speaking.  
② where are you calling from?  
③ there's no one here by that name.
- 4 A: I don't feel well.  
B: ( ) Your face is kind of red.  
A: I think I have a fever. I'd like to go home early.  
① I can see that.  
② I can't understand.  
③ I don't know why.
- 5 A: Where did you practice the piano for the school festival?  
B: I did it in the music classroom at my school. Because ( )  
① I'm good at playing the piano.  
② the piano is very expensive.  
③ I don't have a piano in my house.

V 次の日本語の表す英文となるように ( ) 内の語 (句) を並べかえて正しい英文を作ったとき、( ) 内の、3番目と5番目にくる語 (句) を番号で答えなさい。

- 1 外国語を身につけることはとても大切なことです。  
It ( ① for us ② important ③ is ④ learn ⑤ to ⑥ very ) a foreign language.
- 2 私はあなたがしてくださった事は決して忘れません。  
I'll ( ① you ② what ③ forget ④ never ⑤ did ⑥ for me ).
- 3 病院がどこにあるのか彼に聞いたほうがいいよ。  
You ( ① him ② the hospital ③ ask ④ where ⑤ should ⑥ is ).
- 4 私たちの町には訪れるべき場所がたくさんあります。  
Our ( ① a lot of ② visit ③ city ④ places ⑤ to ⑥ has ).
- 5 私の友達は、「ありがとう」も言わずに家に帰った。  
My friends ( ① "thank you" ② his house ③ went ④ saying ⑤ to ⑥ without ).

VI 次の各組の文がほぼ同じ意味になるように ( ) の中に適切な英単語を入れなさい。

- 1 The movie "Harry Potter" interests young people in Japan.  
Young people ( ) ( ) ( ) the movie "Harry Potter" in Japan.
- 2 What a beautiful picture this is!  
( ) ( ) this picture is!
- 3 I am so young that I can't drive a car.  
I am ( ) young ( ) drive a car.
- 4 Lucy is older than Emily.  
Lucy is not as ( ) ( ) Emily.
- 5 Fifty years have passed since my grandparents married.  
My grandparents have ( ) ( ) for fifty years.

VII 次の英文を読んで、あとの問いに答えなさい。

Leonardo da Vinci began painting the Mona Lisa, which was one of the most famous paintings of all time, in 1503. He was working on a special painting for a church at the time, but it was not going well. The woman who can be seen in the Mona Lisa is said to be Madonna Lisa del Giocondo. She was the wife of an Italian businessman who asked da Vinci to paint a \*portrait of her. After da Vinci finished the painting in 1506, he was invited by the French King, Francois I, to visit France, and he took the painting with him. Today the Mona Lisa is kept in the Louvre, an art museum in Paris, and it is seen by about six million visitors a year.

The painting \*measures only 77 centimeters by 53 centimeters and is painted with oil on wood. In 1911, it was stolen by a worker at the Louvre, Vincenzo Peruggia, who took it out of the museum by hiding it under his coat. Two years later Police found the painting under Peruggia's bed after he tried to sell it.

In 1962, the Mona Lisa was taken to Washington and New York for an \*exhibition. For the \*journey, it was \*insured for 100 million dollars, making it the most valuable painting ever!

(注) portrait : 肖像画    measure : ~の寸法がある    exhibition : 展覧会    journey : 旅    insure : 保険を掛ける

問1 本文の主題として最も適切なものを、a～d から選び記号で答えなさい。

- a Leonardo da Vinci - an Interesting Painter
- b The Louvre - A Famous French Art Museum
- c The Mona Lisa - the Most Valuable Painting of All Time
- d Vincenzo Peruggia - the Man Who Stole the Mona Lisa

問2 次の1～8の文の中から本文の内容に一致するものを4つ選び若い番号順に答えなさい。

- 1 Leonardo da Vinci finished painting the Mona Lisa in 1506.
- 2 Madonna Lisa del Giocondo is said to be the woman in the painting of the Mona Lisa.
- 3 Madonna Lisa del Giocondo is said to be the woman who asked da Vinci to paint the Mona Lisa.
- 4 Leonardo da Vinci went to France to visit the Louvre.
- 5 Leonardo da Vinci was invited by Madonna Lisa del Giocondo.
- 6 Vincenzo Peruggia worked in an art museum.
- 7 Vincenzo Peruggia stole the Mona Lisa.
- 8 Vincenzo Peruggia sold the painting.



志望科	受験番号	氏名
特進コース 普通科 商業科		

(志望科を○で囲みなさい)

I	問1	(1)	(2)	(3)	(4)	(5)	(6)	評点		
	問2	(ア)	(イ)	(ウ)						
		(エ)	(オ)	(カ)						
	問3	1	①	2	②	3	③			
	問4	1		2		3	3番目		5番目	
	問5	1	( ) ( )		2	( ) ( )				
3		( ) ( )		4	( ) ( )					
5		( ) ( )		( ) ( )						
問6	(1)	(2)	(3)	(4)	(5)					
								小計 I		
								小計 II		
								小計 III		
								小計 IV		
II	(1)	(2)								
III	(1)	(2)	(3)							
IV	(1)	(2)	(3)	(4)	(5)					
V		3番目	5番目		3番目	5番目				
	(1)			(2)						
	(3)			(4)						
	(5)							小計 V		
VI	1	( ) ( )		( ) ( )						
	2	( ) ( )		3	( ) ( )					
	4	( ) ( )		5	( ) ( )					
								小計 VI		
VII	問1									
	問2							小計 VII		

◎ 解答はすべて解答用紙に記入しなさい。

1 次の式を計算しなさい。

(1)  $-4 + 11$

(2)  $10 - \{8 - (4 - 7) \times 3\}$

(3)  $\frac{7}{8} \div \frac{5}{4} + \frac{3}{10}$

(4)  $(-5)^2 \div 10 \times 2$

(5)  $(\sqrt{5} - \sqrt{2})(\sqrt{5} + \sqrt{2})$

(6)  $(-3x^2y)^2 \div \frac{9}{10}y$

2 次の方程式・不等式を解きなさい。

(1)  $7x - 2 = 5x + 6$

(2)  $-2x - 12 < 5(0.2x - 1.2)$

(3) 
$$\begin{cases} 2x + 2y = 3x + y \\ 3x - 4y = 1 \end{cases}$$

(4)  $(x - 2)^2 - 6 = 2(x - 1) + 7$

3 次の各問に答えなさい。

(1)  $(x-3):2 = x:4$  のとき、 $x$  の値を求めなさい。

(2)  $\frac{\sqrt{2}}{2}$ ,  $2$ ,  $\sqrt{2}$ ,  $\frac{6}{\sqrt{3}}$  の中で一番大きい数はどれですか。

(3)  $y$  は  $x$  に反比例し、 $x=2$  のとき  $y=6$  です。では  $x=3$  のとき、 $y$  の値を求めなさい。

(4) 2桁の自然数があります。十の位の数と一の位の数を入れ替えた数は、元の数より18小さくなりました。一番小さい元の数を求めなさい。

(5) 右図において、 $\angle CBD=40^\circ$   $\angle CAE=60^\circ$  のとき、 $\angle DFE$ を求めなさい。

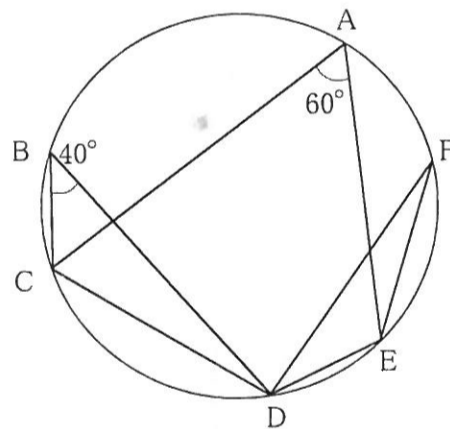

(6) 右の表は兵庫県播磨高等学校サッカー部が夏の大会に参加した10試合の結果を得点別にまとめたものです。この大会の得点数の平均値を求めなさい。

得点数	0	1	2	3	4	5	6
試合数	2	3	1	1	2	0	1

(7) 2個のサイコロを投げたとき、出た目の和が9になる確率を求めなさい。

(8) あるタンクに水を入れます。このタンクを空の状態から丁度一杯にするのに、Aのホースでは8日、Bのホースでは14日かかります。いま、A、Bのホースで、はじめの3日間水を入れ、4日目はAのみ、5日目からはBのホースのみで水を入れていくと、丁度一杯になるのは、水を入れ始めてから何日目ですか。

- (9) 半径6cmの半球A、底面の半径が6cm、高さが $h$ cmの円柱Bがあります。この2つの立体の体積が等しいとき、 $h$ の値を求めなさい。

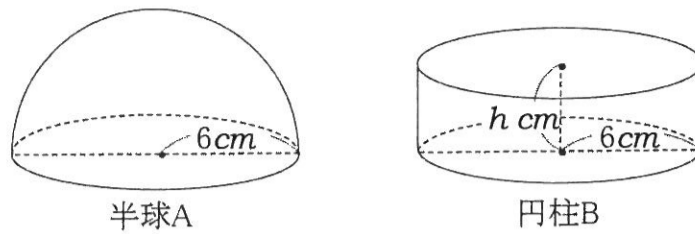

- 4 右の図のように点A(0, 12)があり、直線 $y=12$ と、2つの関数 $y=3x^2$ 、 $y=ax^2$  ( $a > 0$ )のグラフが交わる4点のうち、 $x$ 座標が正である2点をそれぞれB、Cとします。これについて次の間に答えなさい。

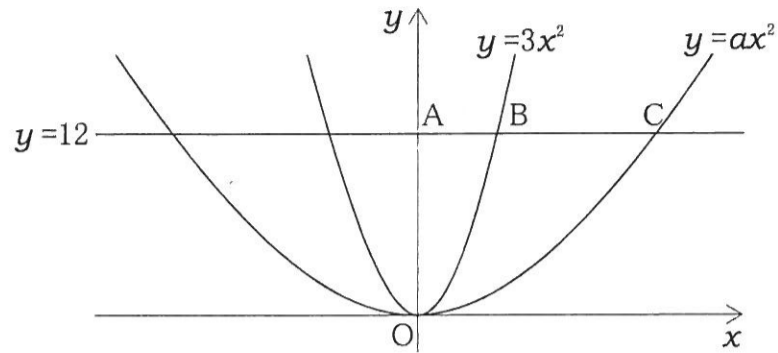

- (1) 点Bの座標を求めなさい。
- (2)  $BC=2AB$ であるとき、 $a$ の値を求めなさい。
- 5 右の図のような一辺が10cmの正方形ABCDがあります。点Pが点Aを出発して辺AB上を秒速1cmで点Bまで動くとき、次の間に答えなさい。

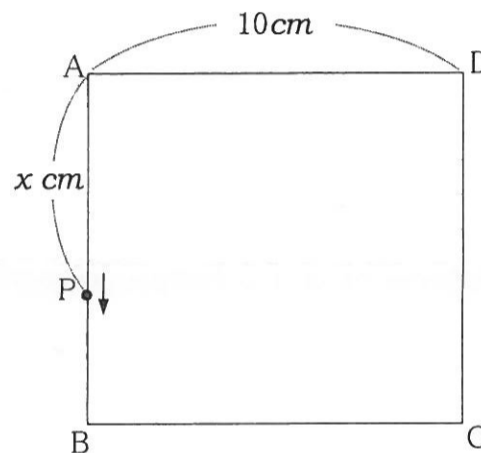

- (1) 点Pが点Aを出発して、 $\triangle PBC$ の面積が $20\text{cm}^2$ になるのは、何秒後ですか。
- (2) 点Qが点Pと同時に点Bを出発して、辺BC上を同じ速さで点Cまで動くとき、 $\triangle DPQ$ の面積が $38\text{cm}^2$ になるのは、点Pが点Aを出発してから何秒後ですか。小さいほうの数字を答えなさい。
- 6 半径1の円 $\text{円}_1$ があります。そこに図のように円 $\text{円}_1$ に接するように半径1の円をかいていきます。結果として円 $\text{円}_1$ の周りに円が6個かけます。これを2周目とします。次に、その2周目の円の周りに3周目の円をかきます。これを4周目まで順にかいていきます。これについて次の間に答えなさい。

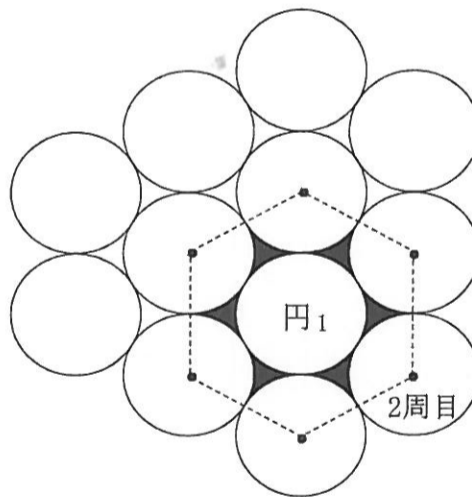

- (1) 1周目から4周目まで、円は全部で何個かけますか。
- (2) 2周目までで、円で囲まれた部分(塗りつぶした部分)の面積を求めなさい。

志望科	受験番号	氏名
特進コース 普通科 商業科		

(志望科を○で囲みなさい。)

1	(1)	
	(2)	
	(3)	
	(4)	
	(5)	
	(6)	
2	(1)	$x =$
	(2)	
	(3)	$x =$ , $y =$
	(4)	$x =$
3	(1)	$x =$
	(2)	
	(3)	$y =$
	(4)	
	(5)	度
	(6)	点
	(7)	
	(8)	日目
	(9)	cm
4	(1)	B ( , )
	(2)	$a =$
5	(1)	秒後
	(2)	秒後
6	(1)	個
	(2)	

評点

小計 1

小計 2

小計 3

小計 4

小計 5

小計 6